

**BR - BS**

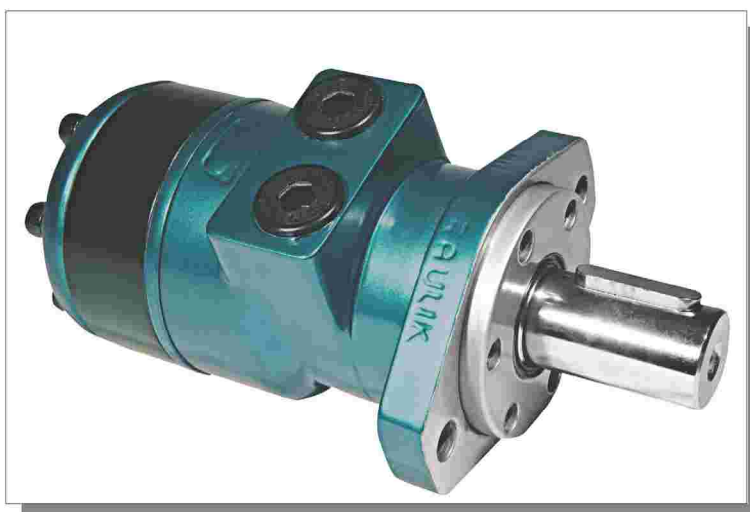

***MOTORI ORBITALI***

**ORBITAL MOTORS**

# CARATTERISTICHE DEL MOTORE MOTOR FEATURES

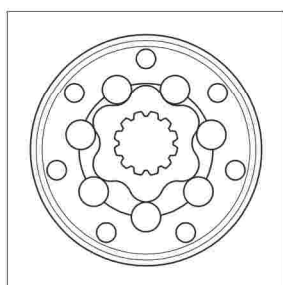
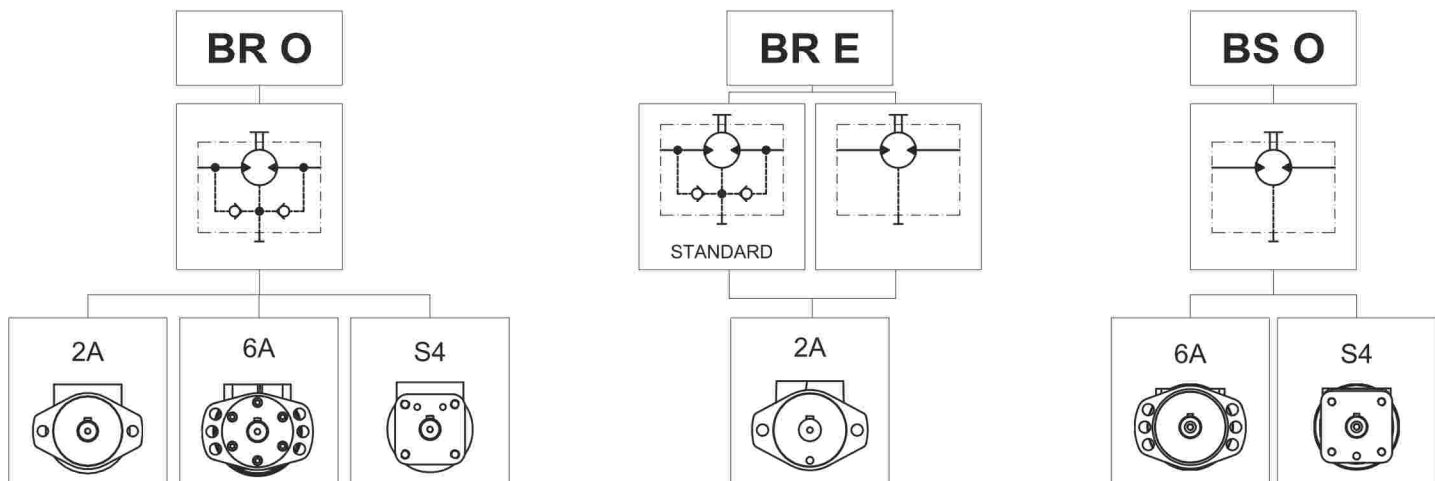

Roller ad alto rendimento per elevate prestazioni e durata.  
High-performance roller for improved efficiency and life.

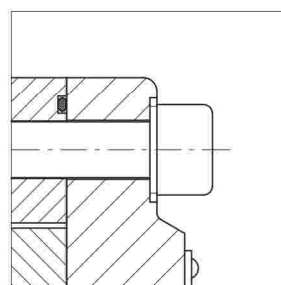

Viti del coperchio posteriore in acciaio ad alta resistenza per sopportare gli sforzi indotti dall'alta pressione.  
High resistance stainless steel screws capable of withstanding the stress induced by high pressure.

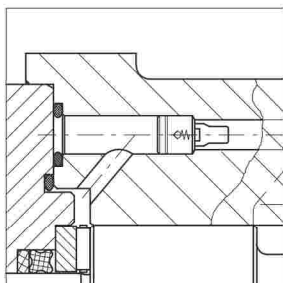

Valvole di drenaggio incorporate: ricircolano allo scarico il fluido drenato internamente.

Built in check valves: to relieve case pressure to the low pressure side of the motor.

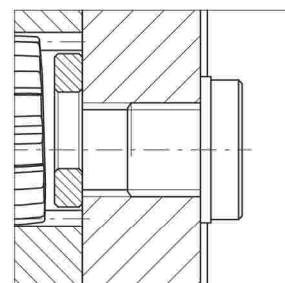

Foro drenaggio posteriore per un facile collegamento.  
Case drain at rear (shown with plug).

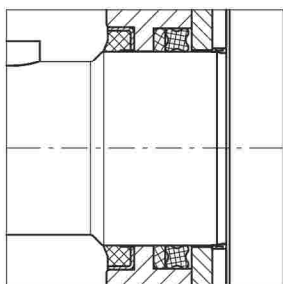

Parapolvere per proteggere la guarnizione di tenuta dell'albero dalle impurità e guarnizione di tenuta ad alte prestazioni.

Dust seal to protect the high pressure shaft seal from dust and debris.

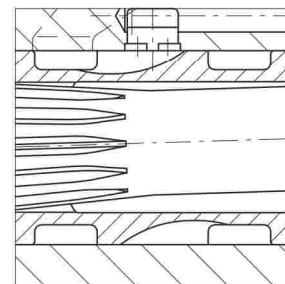
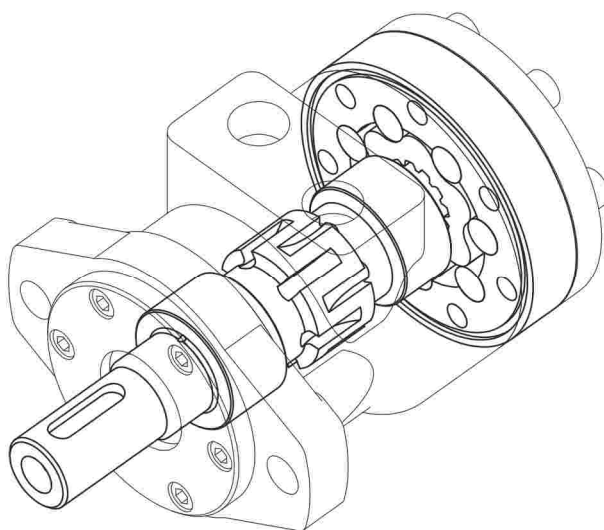

Valvola distributrice radiale ed albero in un solo pezzo con tolleranze ridotte al minimo per assicurare un drenaggio ridotto.

Spool valve integral to the output shaft of new design features optimizing clearance geometry and so minimizing the oil slippage.

**DATI TECNICI PER MOTORE BR CON ALBERI CILINDRICI CL250 E LC254**  
**BR MOTOR TECHNICAL DATA WITH CL250 AND LC254 PARALLEL KEYS SHAFT**

Motore Motor	Cilindrata Displacement cm <sup>3</sup> /rev [in <sup>3</sup> /rev]	Pressione max ingresso Max. input pressure bar [psi]		Pressione diff. max. Max. differential pressure bar [psi]		Coppia max. Max. torque Nm [lbf-ft]		Portata max. Max. flow l/min [U.S. gpm]		Velocità max. Max. speed giri/min [rpm]		Potenza max. Max. power kW [hp]	
		Cont Int <sup>(1)</sup> Peak <sup>(2)</sup>	175 [2537] 200 [2900] 225 [3262]	Cont Int <sup>(1)</sup> Peak <sup>(2)</sup>	140 [2030] 175 [2540] 225 [3262]	Cont Int <sup>(1)</sup>	103 [75.9] 126 [92.8]	Cont Int <sup>(1)</sup>	40 [10.6] 50 [13.2]	Cont Int <sup>(1)</sup>	775 969	Cont Int <sup>(1)</sup>	6.8 [9.1] 8.4 [11.2]
BR 050	51.6 [3.14]	Cont Int <sup>(1)</sup> Peak <sup>(2)</sup>	175 [2537] 200 [2900] 225 [3262]	Cont Int <sup>(1)</sup> Peak <sup>(2)</sup>	140 [2030] 175 [2540] 225 [3262]	Cont Int <sup>(1)</sup>	103 [75.9] 126 [92.8]	Cont Int <sup>(1)</sup>	40 [10.6] 50 [13.2]	Cont Int <sup>(1)</sup>	775 969	Cont Int <sup>(1)</sup>	6.8 [9.1] 8.4 [11.2]
BR 065	64.9 [3.95]	Cont Int <sup>(1)</sup> Peak <sup>(2)</sup>	175 [2537] 200 [2900] 225 [3262]	Cont Int <sup>(1)</sup> Peak <sup>(2)</sup>	150 [2175] 185 [2682] 225 [3262]	Cont Int <sup>(1)</sup>	140 [103.1] 166 [122.3]	Cont Int <sup>(1)</sup>	50 [13.2] 60 [15.9]	Cont Int <sup>(1)</sup>	770 924	Cont Int <sup>(1)</sup>	9.2 [12.3] 10.6 [14.2]
BR 080	80.4 [4.9]	Cont Int <sup>(1)</sup> Peak <sup>(2)</sup>	175 [2537] 200 [2900] 225 [3262]	Cont Int* Peak <sup>(2)</sup>	175 [2537] 200 [2900] 225 [3262]	Cont Int*	197 [145.1] 218 [160.6]	Cont Int <sup>(1)</sup>	60 [15.9] 75 [19.8]	Cont Int <sup>(1)</sup>	746 933	Cont Int <sup>(1)</sup>	13 [17.4] 15 [20.1]
BR 100	100 [6.1]	Cont Int <sup>(1)</sup> Peak <sup>(2)</sup>	175 [2537] 200 [2900] 225 [3262]	Cont Int <sup>(1)</sup> Peak <sup>(2)</sup>	175 [2537] 200 [2900] 225 [3262]	Cont Int <sup>(1)</sup>	237 [174.6] 277 [204.1]	Cont Int <sup>(1)</sup>	60 [15.9] 75 [19.8]	Cont Int <sup>(1)</sup>	600 750	Cont Int <sup>(1)</sup>	13 [17.4] 15 [20.1]
BR 130	125.7 [7.66]	Cont Int <sup>(1)</sup> Peak <sup>(2)</sup>	175 [2537] 200 [2900] 225 [3262]	Cont Int <sup>(1)</sup> Peak <sup>(2)</sup>	175 [2537] 200 [2900] 225 [3262]	Cont Int <sup>(1)</sup>	300 [221.1] 340 [250.5]	Cont Int <sup>(1)</sup>	60 [15.9] 75 [19.8]	Cont Int <sup>(1)</sup>	477 597	Cont Int <sup>(1)</sup>	12.5 [16.8] 14.5 [19.4]
BR 160	160 [9.76]	Cont Int <sup>(1)</sup> Peak <sup>(2)</sup>	175 [2537] 200 [2900] 225 [3262]	Cont Int <sup>(1)</sup> Peak <sup>(2)</sup>	140 [2030] 175 [2540] 225 [3262]	Cont Int <sup>(1)</sup>	296 [218.1] 375 [276.3]	Cont Int <sup>(1)</sup>	60 [15.9] 75 [19.8]	Cont Int <sup>(1)</sup>	375 469	Cont Int <sup>(1)</sup>	10 [13.4] 12.5 [16.8]
BR 200	200 [12.2]	Cont Int <sup>(1)</sup> Peak <sup>(2)</sup>	175 [2537] 200 [2900] 225 [3262]	Cont Int <sup>(1)</sup> Peak <sup>(2)</sup>	115 [1667] 140 [2030] 225 [3262]	Cont Int <sup>(1)</sup>	297 [218.8] 380 [280]	Cont Int <sup>(1)</sup>	60 [15.9] 75 [19.8]	Cont Int <sup>(1)</sup>	300 375	Cont Int <sup>(1)</sup>	8.5 [11] 10 [13.4]
BR 250	250 [15.2]	Cont Int <sup>(1)</sup> Peak <sup>(2)</sup>	175 [2537] 200 [2900] 225 [3262]	Cont Int <sup>(1)</sup> Peak <sup>(2)</sup>	90 [1305] 120 [1740] 225 [3262]	Cont Int <sup>(1)</sup>	297 [218.8] 377 [277.8]	Cont Int <sup>(1)</sup>	60 [15.9] 75 [19.8]	Cont Int <sup>(1)</sup>	240 300	Cont Int <sup>(1)</sup>	7.1 [9.5] 8.5 [11]
BR 315	314.5 [19.1]	Cont Int <sup>(1)</sup> Peak <sup>(2)</sup>	175 [2537] 200 [2900] 225 [3262]	Cont Int <sup>(1)</sup> Peak <sup>(2)</sup>	70 [1020] 100 [1450] 210 [3045]	Cont Int <sup>(1)</sup>	300 [221.1] 420 [309.5]	Cont Int <sup>(1)</sup>	60 [15.9] 75 [19.8]	Cont Int <sup>(1)</sup>	191 238	Cont Int <sup>(1)</sup>	5 [6.7] 6.6 [8.8]
BR 400	393 [23.9]	Cont Int <sup>(1)</sup> Peak <sup>(2)</sup>	175 [2537] 200 [2900] 225 [3262]	Cont Int <sup>(1)</sup> Peak <sup>(2)</sup>	55 [800] 85 [1230] 175 [2537]	Cont Int <sup>(1)</sup>	292 [215.2] 425 [313.2]	Cont Int <sup>(1)</sup>	60 [15.9] 75 [19.8]	Cont Int <sup>(1)</sup>	153 191	Cont Int <sup>(1)</sup>	4.1 [5.4] 6.1 [8.1]

**DATI TECNICI PER MOTORE BR CON ALBERO SCANALATO SD250**  
**BR MOTOR TECHNICAL DATA WITH SD250 SPLINED SHAFT**

Motore Motor	Cilindrata Displacement cm <sup>3</sup> /rev [in <sup>3</sup> /rev]	Pressione max ingresso Max. input pressure bar [psi]		Pressione diff. max. Max. differential pressure bar [psi]		Coppia max. Max. torque Nm [lbf-ft]		Portata max. Max. flow l/min [U.S. gpm]		Velocità max. Max. speed giri/min [rpm]		Potenza max. Max. power kW [hp]	
		Cont Int <sup>(1)</sup> Peak <sup>(2)</sup>	175 [2537] 200 [2900] 225 [3262]	Cont Int <sup>(1)</sup> Peak <sup>(2)</sup>	140 [2030] 175 [2540] 225 [3262]	Cont Int <sup>(1)</sup>	103 [75.9] 126 [92.8]	Cont Int <sup>(1)</sup>	40 [10.6] 50 [13.2]	Cont Int <sup>(1)</sup>	775 969	Cont Int <sup>(1)</sup>	6.8 [9.1] 8.4 [11.2]
BR 050	51.6 [3.14]	Cont Int <sup>(1)</sup> Peak <sup>(2)</sup>	175 [2537] 200 [2900] 225 [3262]	Cont Int <sup>(1)</sup> Peak <sup>(2)</sup>	140 [2030] 175 [2540] 225 [3262]	Cont Int <sup>(1)</sup>	103 [75.9] 126 [92.8]	Cont Int <sup>(1)</sup>	40 [10.6] 50 [13.2]	Cont Int <sup>(1)</sup>	775 969	Cont Int <sup>(1)</sup>	6.8 [9.1] 8.4 [11.2]
BR 065	64.9 [3.95]	Cont Int <sup>(1)</sup> Peak <sup>(2)</sup>	175 [2537] 200 [2900] 225 [3262]	Cont Int <sup>(1)</sup> Peak <sup>(2)</sup>	150 [2175] 185 [2682] 225 [3262]	Cont Int <sup>(1)</sup>	140 [103.1] 166 [122.3]	Cont Int <sup>(1)</sup>	50 [13.2] 60 [15.9]	Cont Int <sup>(1)</sup>	770 924	Cont Int <sup>(1)</sup>	9.2 [12.3] 10.6 [14.2]
BR 080	80.4 [4.9]	Cont Int <sup>(1)</sup> Peak <sup>(2)</sup>	175 [2537] 200 [2900] 225 [3262]	Cont Int* Peak <sup>(2)</sup>	175 [2537] 200 [2900] 225 [3262]	Cont Int*	197 [145.1] 218 [160.6]	Cont Int <sup>(1)</sup>	60 [15.9] 75 [19.8]	Cont Int <sup>(1)</sup>	746 933	Cont Int <sup>(1)</sup>	13 [17.4] 15 [20.1]
BR 100	100 [6.1]	Cont Int <sup>(1)</sup> Peak <sup>(2)</sup>	175 [2537] 200 [2900] 225 [3262]	Cont Int <sup>(1)</sup> Peak <sup>(2)</sup>	175 [2537] 200 [2900] 225 [3262]	Cont Int <sup>(1)</sup>	237 [174.6] 277 [204.1]	Cont Int <sup>(1)</sup>	60 [15.9] 75 [19.8]	Cont Int <sup>(1)</sup>	600 750	Cont Int <sup>(1)</sup>	13 [17.4] 15 [20.1]
BR 130	125.7 [7.66]	Cont Int <sup>(1)</sup> Peak <sup>(2)</sup>	175 [2537] 200 [2900] 225 [3262]	Cont Int <sup>(1)</sup> Peak <sup>(2)</sup>	175 [2537] 200 [2900] 225 [3262]	Cont Int <sup>(1)</sup>	300 [221.1] 340 [250.5]	Cont Int <sup>(1)</sup>	60 [15.9] 75 [19.8]	Cont Int <sup>(1)</sup>	477 597	Cont Int <sup>(1)</sup>	12.5 [16.8] 14.5 [19.4]
BR 160	160 [9.76]	Cont Int <sup>(1)</sup> Peak <sup>(2)</sup>	175 [2537] 200 [2900] 225 [3262]	Cont Int <sup>(1)</sup> Peak <sup>(2)</sup>	165 [2390] 200 [2900] 225 [3262]	Cont Int <sup>(1)</sup>	350 [257.9] 428 [315.4]	Cont Int <sup>(1)</sup>	60 [15.9] 75 [19.8]	Cont Int <sup>(1)</sup>	375 469	Cont Int <sup>(1)</sup>	11.8 [15.8] 14.3 [19.1]
BR 200	200 [12.2]	Cont Int <sup>(1)</sup> Peak <sup>(2)</sup>	175 [2537] 200 [2900] 225 [3262]	Cont Int <sup>(1)</sup> Peak <sup>(2)</sup>	130 [1890] 165 [2390] 225 [3262]	Cont Int <sup>(1)</sup>	335 [246.8] 446 [328.7]	Cont Int <sup>(1)</sup>	60 [15.9] 75 [19.8]	Cont Int <sup>(1)</sup>	300 375	Cont Int <sup>(1)</sup>	9.7 [12.9] 12 [16]
BR 250	250 [15.2]	Cont Int <sup>(1)</sup> Peak <sup>(2)</sup>	175 [2537] 200 [2900] 225 [3262]	Cont Int <sup>(1)</sup> Peak <sup>(2)</sup>	105 [1522] 135 [1957] 225 [3262]	Cont Int <sup>(1)</sup>	347 [255.7] 424 [312.4]	Cont Int <sup>(1)</sup>	60 [15.9] 75 [19.8]	Cont Int <sup>(1)</sup>	240 300	Cont Int <sup>(1)</sup>	8.3 [11.1] 9.6 [12.8]
BR 315	314.5 [19.1]	Cont Int <sup>(1)</sup> Peak <sup>(2)</sup>	175 [2537] 200 [2900] 225 [3262]	Cont Int <sup>(1)</sup> Peak <sup>(2)</sup>	85 [1232] 115 [1670] 210 [3045]	Cont Int <sup>(1)</sup>	362 [266.7] 484 [356.7]	Cont Int <sup>(1)</sup>	60 [15.9] 75 [19.8]	Cont Int <sup>(1)</sup>	191 238	Cont Int <sup>(1)</sup>	6 [8] 7.6 [10.1]
BR 400	393 [23.9]	Cont Int <sup>(1)</sup> Peak <sup>(2)</sup>	175 [2537] 200 [2900] 225 [3262]	Cont Int <sup>(1)</sup> Peak <sup>(2)</sup>	65 [942] 90 [1310] 175 [2537]	Cont Int <sup>(1)</sup>	345 [254.2] 450 [331.6]	Cont Int <sup>(1)</sup>	60 [15.9] 75 [19.8]	Cont Int <sup>(1)</sup>	153 191	Cont Int <sup>(1)</sup>	4.9 [6.5] 6.5 [8.7]



**DATI TECNICI PER MOTORE BR CON ALBERI CILINDRICI CL320, C3175 E CONICO CN320**  
**BR MOTOR TECHNICAL DATA WITH CL320, C3175 PARALLEL KEYED SHAFT AND CN320 TAPERED SHAFT**

Motore Motor	Cilindrata Displacement cm <sup>3</sup> /rev [in <sup>3</sup> /rev]	Pressione max ingresso Max. input pressure bar [psi]		Pressione diff. max. Max. differential pressure bar [psi]		Coppia max. Max. torque Nm [lbf-ft]		Portata max. Max. flow l/min [U.S. gpm]		Velocità max. Max. speed giri/min [rpm]		Potenza max. Max. power kW [hp]	
		Cont Int <sup>1)</sup> Peak <sup>2)</sup>	175 [2537] 200 [2900] 225 [3262]	Cont Int <sup>1)</sup> Peak <sup>2)</sup>	140 [2030] 175 [2540] 225 [3262]	Cont Int <sup>1)</sup>	103 [75.9] 126 [92.8]	Cont Int <sup>1)</sup>	40 [10.6] 50 [13.2]	Cont Int <sup>1)</sup>	775 969	Cont Int <sup>1)</sup>	6.8 [9.1] 8.4 [11.2]
BR 050	51.6 [3.14]	Cont Int <sup>1)</sup> Peak <sup>2)</sup>	175 [2537] 200 [2900] 225 [3262]	Cont Int <sup>1)</sup> Peak <sup>2)</sup>	140 [2030] 175 [2540] 225 [3262]	Cont Int <sup>1)</sup>	103 [75.9] 126 [92.8]	Cont Int <sup>1)</sup>	40 [10.6] 50 [13.2]	Cont Int <sup>1)</sup>	775 969	Cont Int <sup>1)</sup>	6.8 [9.1] 8.4 [11.2]
BR 065	64.9 [3.95]	Cont Int <sup>1)</sup> Peak <sup>2)</sup>	175 [2537] 200 [2900] 225 [3262]	Cont Int <sup>1)</sup> Peak <sup>2)</sup>	150 [2175] 185 [2682] 225 [3262]	Cont Int <sup>1)</sup>	140 [103.1] 166 [122.3]	Cont Int <sup>1)</sup>	50 [13.2] 60 [15.9]	Cont Int <sup>1)</sup>	770 924	Cont Int <sup>1)</sup>	9.2 [12.3] 10.6 [14.2]
BR 080	80.4 [4.9]	Cont Int <sup>1)</sup> Peak <sup>2)</sup>	175 [2537] 200 [2900] 225 [3262]	Cont Int* Peak <sup>2)</sup>	175 [2537] 200 [2900] 225 [3262]	Cont Int*	197 [145.1] 218 [160.6]	Cont Int <sup>1)</sup>	60 [15.9] 75 [19.8]	Cont Int <sup>1)</sup>	746 933	Cont Int <sup>1)</sup>	13 [17.4] 15 [20.1]
BR 100	100 [6.1]	Cont Int <sup>1)</sup> Peak <sup>2)</sup>	175 [2537] 200 [2900] 225 [3262]	Cont Int <sup>1)</sup> Peak <sup>2)</sup>	175 [2537] 200 [2900] 225 [3262]	Cont Int <sup>1)</sup>	237 [174.6] 277 [204.1]	Cont Int <sup>1)</sup>	60 [15.9] 75 [19.8]	Cont Int <sup>1)</sup>	600 750	Cont Int <sup>1)</sup>	13 [17.4] 15 [20.1]
BR 130	125.7 [7.66]	Cont Int <sup>1)</sup> Peak <sup>2)</sup>	175 [2537] 200 [2900] 225 [3262]	Cont Int <sup>1)</sup> Peak <sup>2)</sup>	175 [2537] 200 [2900] 225 [3262]	Cont Int <sup>1)</sup>	300 [221.1] 340 [250.5]	Cont Int <sup>1)</sup>	60 [15.9] 75 [19.8]	Cont Int <sup>1)</sup>	477 597	Cont Int <sup>1)</sup>	12.5 [16.8] 14.5 [19.4]
BR 160	160 [9.76]	Cont Int <sup>1)</sup> Peak <sup>2)</sup>	175 [2537] 200 [2900] 225 [3262]	Cont Int <sup>1)</sup> Peak <sup>2)</sup>	175 [2537] 200 [2900] 225 [3262]	Cont Int <sup>1)</sup>	370 [272.6] 428 [315.4]	Cont Int <sup>1)</sup>	60 [15.9] 75 [19.8]	Cont Int <sup>1)</sup>	375 469	Cont Int <sup>1)</sup>	12.5 [16.8] 14.3 [19.1]
BR 200	200 [12.2]	Cont Int <sup>1)</sup> Peak <sup>2)</sup>	175 [2537] 200 [2900] 225 [3262]	Cont Int <sup>1)</sup> Peak <sup>2)</sup>	175 [2537] 200 [2900] 225 [3262]	Cont Int <sup>1)</sup>	450 [331.6] 540 [397.9]	Cont Int <sup>1)</sup>	60 [15.9] 75 [19.8]	Cont Int <sup>1)</sup>	300 375	Cont Int <sup>1)</sup>	13.4 [17.9] 14.4 [19.2]
BR 250	250 [15.2]	Cont Int <sup>1)</sup> Peak <sup>2)</sup>	175 [2537] 200 [2900] 225 [3262]	Cont Int <sup>1)</sup> Peak <sup>2)</sup>	175 [2537] 200 [2900] 225 [3262]	Cont Int <sup>1)</sup>	578 [425.9] 630 [464.3]	Cont Int <sup>1)</sup>	60 [15.9] 75 [19.8]	Cont Int <sup>1)</sup>	240 300	Cont Int <sup>1)</sup>	13.8 [18.4] 14.2 [19]
BR 315	314.5 [19.1]	Cont Int <sup>1)</sup> Peak <sup>2)</sup>	175 [2537] 200 [2900] 225 [3262]	Cont Int <sup>1)</sup> Peak <sup>2)</sup>	135 [1960] 175 [2537] 210 [3045]	Cont Int <sup>1)</sup>	575 [423.7] 736 [542.4]	Cont Int <sup>1)</sup>	60 [15.9] 75 [19.8]	Cont Int <sup>1)</sup>	191 238	Cont Int <sup>1)</sup>	9.6 [12.8] 11.5 [15.4]
BR 400	393 [23.9]	Cont Int <sup>1)</sup> Peak <sup>2)</sup>	175 [2537] 200 [2900] 225 [3262]	Cont Int <sup>1)</sup> Peak <sup>2)</sup>	115 [1670] 150 [2180] 175 [2537]	Cont Int <sup>1)</sup>	612 [451] 750 [552.7]	Cont Int <sup>1)</sup>	60 [15.9] 75 [19.8]	Cont Int <sup>1)</sup>	153 191	Cont Int <sup>1)</sup>	8.6 [11.5] 10.8 [14.4]

Motore Motor	Max press. di scarico con drenaggio aperto Max back pressure with drain line bar[psi]		Pressione max avviamento a vuoto Max starting pressure in unloaded conditions bar[psi]		Coppia min di spunto Min starting torque Nm[lbf-ft]		Portata di drenaggio <sup>4)</sup> Oil flow in the drain line <sup>4)</sup> l/min [U.S. gpm]		Velocità minima <sup>5)</sup> Min speed <sup>5)</sup> rpm	
	Cont Int <sup>1)</sup> Peak <sup>2)</sup>	175 [2538] 200 [2900] 225 [3263]	10 [145]	at Δp max at Δp max	Cont Int*	75[55.3] 95[70.0]	at Δp=100bar[1450psi] at Δp=140bar[2030psi]	0.7[0.2] 1.6[0.4]	10	
BR 050	Cont Int <sup>1)</sup> Peak <sup>2)</sup>	175 [2538] 200 [2900] 225 [3263]	10 [145]	at Δp max at Δp max	Cont Int*	75[55.3] 95[70.0]	at Δp=100bar[1450psi] at Δp=140bar[2030psi]	0.7[0.2] 1.6[0.4]	10	
BR 065	Cont Int <sup>1)</sup> Peak <sup>2)</sup>	175 [2538] 200 [2900] 225 [3263]	10 [145]	at Δp max at Δp max	Cont Int*	120[88.4] 140[103.1]	at Δp=100bar[1450psi] at Δp=140bar[2030psi]	0.7[0.2] 1.6[0.4]	10	
BR 080	Cont Int <sup>1)</sup> Peak <sup>2)</sup>	175 [2538] 200 [2900] 225 [3263]	10 [145]	at Δp max at Δp max	Cont Int*	160[118] 180[133]	at Δp=100bar[1450psi] at Δp=140bar[2030psi]	0.7[0.2] 1.6[0.4]	10	
BR 100	Cont Int <sup>1)</sup> Peak <sup>2)</sup>	175 [2538] 200 [2900] 225 [3263]	10 [145]	at Δp max at Δp max	Cont Int*	200[147] 225[166]	at Δp=100bar[1450psi] at Δp=140bar[2030psi]	0.7[0.2] 1.6[0.4]	10	
BR 130	Cont Int <sup>1)</sup> Peak <sup>2)</sup>	175 [2538] 200 [2900] 225 [3263]	9 [131]	at Δp max at Δp max	Cont Int*	255[188] 290[214]	at Δp=100bar[1450psi] at Δp=140bar[2030psi]	0.7[0.2] 1.6[0.4]	10	
BR 160	Cont Int <sup>1)</sup> Peak <sup>2)</sup>	175 [2538] 200 [2900] 225 [3263]	7 [102]	at Δp max at Δp max	Cont Int*	310(250)[228(184)] <sup>3)</sup> 360(300)[265(221)] <sup>3)</sup>	at Δp=100bar[1450psi] at Δp=140bar[2030psi]	0.7[0.2] 1.6[0.4]	10	
BR 200	Cont Int <sup>1)</sup> Peak <sup>2)</sup>	175 [2538] 200 [2900] 225 [3263]	5 [72.5]	at Δp max at Δp max	Cont Int*	390(250)[287(184)] <sup>3)</sup> 450(320)[332(236)] <sup>3)</sup>	at Δp=100bar[1450psi] at Δp=140bar[2030psi]	1.5[0.4] 3.0[0.8]	10	
BR 250	Cont Int <sup>1)</sup> Peak <sup>2)</sup>	175 [2538] 200 [2900] 225 [3263]	5 [72.5]	at Δp max at Δp max	Cont Int*	490(250)[361(184)] <sup>3)</sup> 560(310)[413(228)] <sup>3)</sup>	at Δp=100bar[1450psi] at Δp=140bar[2030psi]	1.5[0.4] 3.0[0.8]	10	
BR 315	Cont Int <sup>1)</sup> Peak <sup>2)</sup>	175 [2538] 200 [2900] 225 [3263]	5 [72.5]	at Δp max at Δp max	Cont Int*	470(250)[346(184)] <sup>3)</sup> 610(300)[450(221)] <sup>3)</sup>	at Δp=100bar[1450psi] at Δp=140bar[2030psi]	1.5[0.4] 3.0[0.8]	10	
BR 400	Cont Int <sup>1)</sup> Peak <sup>2)</sup>	175 [2538] 200 [2900] 225 [3263]	5 [72.5]	at Δp max at Δp max	Cont Int*	510(250)[376(184)] <sup>3)</sup> 670(320)[494(236)] <sup>3)</sup>	at Δp=100bar[1450psi] at Δp=140bar[2030psi]	1.5[0.4] 3.0[0.8]	10	

1) Le condizioni intermittenti non devono durare più del 10% ogni minuto. - Intermittent duty must not exceed 10% each minute. 2) Le condizioni di picco non devono durare più del 1% di ogni minuto. - Peak duty must not exceed 1% each minute. 3) I valori tra parentesi si riferiscono alla versione con albero CL250/LC254/SD250. - The values in brackets are referred to CL250/LC254/SD250 shaft. 4) Viscosità dell'olio 37 cSt. - Oil Viscosity 37 cSt. 5) Per impieghi a velocità inferiori o con carichi radiali consultare la S.A.M. Hydraulic for applications at lower rpm or at high radial loads pls. consult S.A.M. Hydraulic.

# MASSIMA PRESSIONE AMMESSA SULLA GUARNIZIONE ALBERO MAX PERMISSIBLE SHAFT SEAL PRESSURE

Pressione massima di scarico senza drenaggio o massima pressione nella linea di drenaggio. I motori sono forniti nella versione con guarnizioni standard (diagramma Standard) o nella versione con guarnizioni ad alta pressione (diagramma HPS). Per condizioni di pressione e velocità non contemplate dal presente grafico si consiglia di contattare la S.A.M. Hydraulik.

N.B.: Sulle versioni con Tachimetro o Freno non è possibile installare guarnizioni HPS.

Max. return pressure without drain line or max. pressure in the drain line. Motor are supplied in standard seal version (Standard chart) or in HPS seal version (HPS chart). For pressure and speeds not showed in the curve below, please contact S.A.M. Hydraulik.

N.B.: Tachometer or Brake versions is not available with HPS seals.

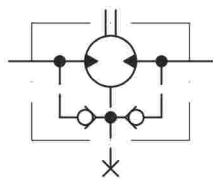
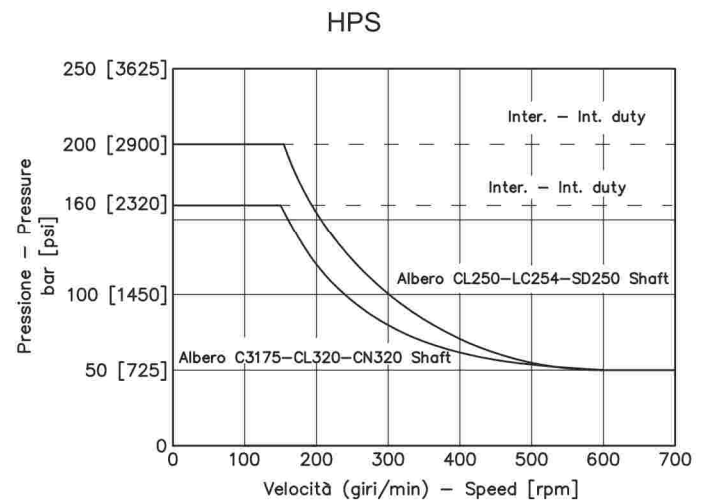
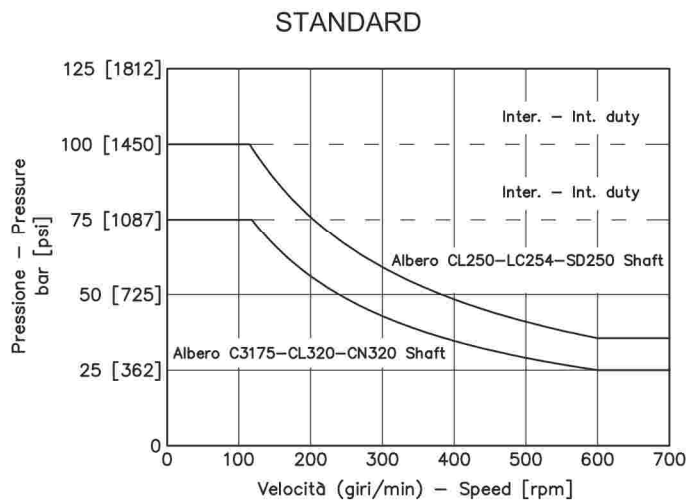

# PERDITE DI CARICO PER ATTRAVERSAMENTO PRESSURE LOSS

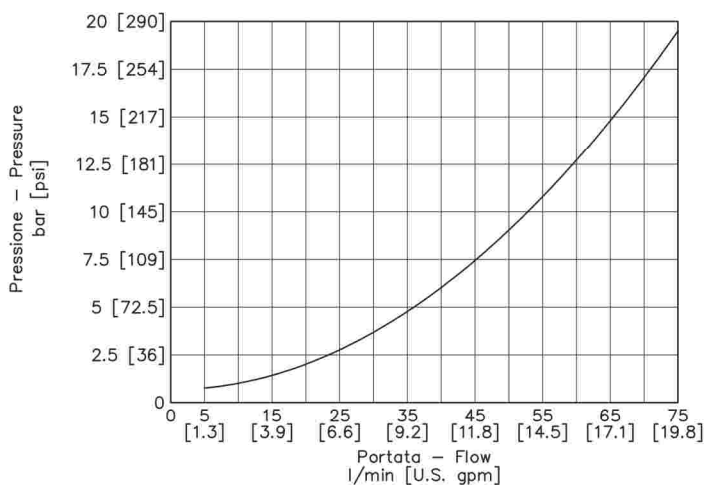

Il diagramma è stato ottenuto con prove eseguite su un numero significativo di motori, utilizzando un olio avente una viscosità cinematica di 37 cSt alla temperatura di 45° C.

Curve according tests carried out with a relevant number of motors and using hydraulic oil with cinematic viscosity of 37 cSt at 45° C temperature.

# CODICI DI ORDINAZIONE ORDERING CODES

Le seguenti lettere o numeri del codice, sono state sviluppate per identificare tutte le configurazioni possibili dei motori BR. Usare il seguente modulo per identificare le caratteristiche desiderate. **Tutte le lettere o numeri del codice devono comparire in fase d'ordine.** Si consiglia di leggere attentamente il catalogo prima di iniziare la compilazione del codice di ordinazione.

The following alphanumeric digits system has been developed to identify all of the configuration options for the BR motors. Use the model code below to specify the desired features. **All alphanumeric digits system of the code must be present when ordering.** We recommend to carefully read the catalogue before filling the ordering code.

## CODICE PRODOTTO / MODEL CODE

1	2	3	4	5	6	7	8	8A	9	10

### 1 - SERIE / SERIES

BR	Motore orbitale Orbital motor
----	----------------------------------

### 2 - VERSIONI / VERSIONS

E	Versione E E Version	
O	Versione O O Version	STANDARD

### 3 - CILINDRATA / DISPLACEMENT

050	51.6 cm <sup>3</sup> /giro [3.14 in <sup>3</sup> /rev]
065	64.9 cm <sup>3</sup> /giro [3.95 in <sup>3</sup> /rev]
080	80.4 cm <sup>3</sup> /giro [4.9 in <sup>3</sup> /rev]
100	100 cm <sup>3</sup> /giro [6.1 in <sup>3</sup> /rev]
130	125.7 cm <sup>3</sup> /giro [7.66 in <sup>3</sup> /rev]
160	160 cm <sup>3</sup> /giro [9.76 in <sup>3</sup> /rev]
200	200 cm <sup>3</sup> /giro [12.2 in <sup>3</sup> /rev]
250	250 cm <sup>3</sup> /giro [15.2 in <sup>3</sup> /rev]
315	314.5 cm <sup>3</sup> /giro [19.1 in <sup>3</sup> /rev]
400	393 cm <sup>3</sup> /giro [23.9 in <sup>3</sup> /rev]

### 4 - FLANGIA / MOUNTING FLANGE

			VERSIONI / VERSIONS	
			E	O
2A	Ovale 2 Fori Oval 2 Bolts	STANDARD	•	•
6A	Ovale 6 Fori Oval 6 Bolts		/	•
S4	4 fori 3/8 16 UNC - Ø44,45mm 4 Bolt 3/8 16 UNC - Ø1.75 in	Speciale a richiesta Special on request	/	•

• Disponibile - Available / Non Disponibile - Not Available



1	2	3	4	5	6	7	8	8A	9	10

## 5 - ATTACCHI / MAIN PORTS

			VERSIONI / VERSIONS	
			E	O
M08	Attacchi 1/2 G BSPP (40x8) 1/2 G BSPP (40x8) Main Ports	STANDARD	/	•
R08	Attacchi 1/2 G BSPP (36x36) 1/2 G BSPP (36x36) Main Ports		•	/

• Disponibile - Available / Non Disponibile - Not Available

## 6 - ESTREMITÀ ALBERO / OUTPUT SHAFT

			VERSIONI / VERSIONS			
			E		O	
			FLANGIA FLANGE		FLANGIA FLANGE	
		2A	2A	6A	S4	
CL250	Albero Cilindrico Ø25 mm 0.984 in Parallel keyed	STANDARD	•	•	•	
LC254	Albero Cilindrico Ø25.4 mm 1 in Parallel keyed		•	•	•	
C3175	Albero Cilindrico Ø31.75 mm 1.25 in Parallel keyed		/	/	/	
CL320	Albero Cilindrico Ø32 mm 1.259 in Parallel keyed		/	/	/	
CN320	Albero Conico Tapered Shaft	Speciale a richiesta Special on request	/	/	/	
SD250	Albero Scanalato (profilo SAE 6B 1" Z6) Splined Shaft (SAE 6B 1" 6T spline)		•	•	•	

• Disponibile - Available / Non Disponibile - Not Available

## 7 - TENUTE / SEALS

N	NBR	STANDARD
V	FKM	

## 8 - VALVOLE / VALVES

			ATTACCHI / MAIN PORTS	
			M08	R08
XXXX	Non Richieste Not Required	STANDARD	•	•
M081	Valvola di massima pressione VAF 08 - D VAF 08 - D pressure relief valve		•	/
M082	Valvola di massima pressione VAF 08 - D/AF VAF 08 - D/AF pressure relief valve		•	/
M083	Valvola Antiurto e Anticavitazione VAAF 31 VAAF 31 anticavitation and Anti-Shock Valve		•	/
M084	Valvola con prelievo del fluido in pressione AF AF shuttle-valve		•	/
M085	Valvola bilanciata di blocco e controllo discesa VCD 08 - S/AF VCD 08 - S/AF overcentre Valve		•	/
M086	Valvola di controllo bilanciata a doppio effetto VCR1 08 - D/AF VCR1 08 - D/AF double-acting overcentre valve with shuttle valve		•	/
M087	Valvola di controllo bilanciata a doppio effetto con valvola limitatrice di pressione VCR1 08 D/AF LDP VCR1 08 D/AF LDP double-acting overcentre valve with shuttle valve		•	/
R081 <sup>(1)</sup>	Valvola di massima pressione VAF E8 - D VAF E8 - D pressure relief valve		/	•
R082 <sup>(1)</sup>	Valvola bilanciata di blocco e controllo discesa VCD E8 - S/AF VCD E8 - S/AF overcentre Valve		/	•
R083 <sup>(1)</sup>	Valvola di controllo bilanciata a doppio effetto VCR1 E8 - D/AF VCR1 E8 - D/AF double-acting overcentre valve with shuttle valve		/	•
R084 <sup>(1)</sup>	Valvola di controllo bilanciata a doppio effetto con valvola limitatrice di pressione VCR1 E8 D/AF LDP VCR1 E8 D/AF LDP double-acting overcentre valve with shuttle valve		/	•

• Disponibile - Available / Non Disponibile - Not Available

(1) Attenzione: quantità minima per ordine 20 pezzi  
(1) Warning: minimum quantity for order 20 pieces

1	2	3	4	5	6	7	8	8A	9	10

### 8A - CARATTERISTICA VALVOLA / VALVES FEATURE

			VALVOLE / VALVES											
			XXXX	M081	M082	M083	M084	M085	M086	M087	R081	R082	R083	R084
000	Caratteristica non necessaria Feature not necessary	STANDARD	●	/	/	/	●	/	/	/	/	/	/	/
001	Non Tarata (Campo Taratura 30+70 bar) Not Set [435 to 1015 psi]		/	●	●	/	/	/	/	/	/	/	/	/
002	Non Tarata (Campo Taratura 70+200 bar) Not Set [1015 to 2900 psi]		/	●	●	/	/	/	/	/	/	/	/	/
003	Non Tarata (Campo Taratura 50+130 bar) Not Set [725 to 1885 psi]		/	/	/	●	/	/	/	/	●	/	/	/
004	Non Tarata (Campo Taratura 100+250 bar) Not Set [1450 to 3625 psi]		/	/	/	●	/	/	/	/	/	/	/	/
007	Non Tarata (Campo Taratura 100+200 bar) Not Set [1450 to 2900 psi]		/	/	/	/	/	/	/	/	●	/	/	/
425	Rapporto di Pilotaggio 4.25:1 Pilot Ratio 4.25:1		/	/	/	/	/	/	●	●	/	/	●	●
800	Rapporto di Pilotaggio 8:1 Pilot Ratio 8:1		/	/	/	/	/	/	●	●	/	/	/	/
70D	Rapporto di Pilotaggio 7:1 - Senso di rotazione DX Pilot Ratio 7:1 - Direction of rotation CW		/	/	/	/	/	●	/	/	/	/	/	/
35D	Rapporto di Pilotaggio 3.5:1 - Senso di rotazione DX Pilot Ratio 3.5:1 - Direction of rotation CW		/	/	/	/	/	●	/	/	/	●	/	/
70S	Rapporto di Pilotaggio 7:1 - Senso di rotazione SX Pilot Ratio 7:1 - Direction of rotation CCW		/	/	/	/	/	●	/	/	/	/	/	/
35S	Rapporto di Pilotaggio 3.5:1 - Senso di rotazione SX Pilot Ratio 3.5:1 - Direction of rotation CCW		/	/	/	/	/	●	/	/	/	●	/	/

● Disponibile - Available / Non Disponibile - Not Available

Per la fornitura di valvole tarate contattare Uff. Tecnico.  
Please contact Technical department for valve which require specific setting

### 9 - CARATTERISTICA VERSIONE / VERSION FEATURE

			VERSIONI / VERSIONS	
			E	O
XXX	Versione base + Drenaggio posteriore - 1/4 G (BSPP) Standard version + Rear Drain - 1/4 G (BSPP)	STANDARD	●	●
HPS	Guarnizione alta pressione (senza Drenaggio posteriore) High Pressure Seal (without Rear Drain)		●	●
TC1	Tachimetro TAC/U (con predisposizione per sensore) TAC/U tachometer (with sensor arrangement)		/	●
TC4	Tachimetro TAC/M TAC/M tachometer		/	●
TC5	Tachimetro TAC/M-E (con predisposizione per sensore) TAC/M-E tachometer (with sensor arrangement)		/	●
SV0	Versione senza valvole di drenaggio interne + Drenaggio posteriore - 1/4 G (BSPP) Version without built-in check valves + Rear Drain - 1/4 G (BSPP)		●	/
SVH	Versione senza valvole di drenaggio interne + Guarnizione alta pressione (senza Drenaggio posteriore) Version without built-in check valves + High Pressure Seal (without Rear Drain)		●	/
SVA	Versione senza valvole di drenaggio interne + Guarnizione alta pressione + Drenaggio posteriore - 1/4 G (BSPP) Version without built-in check valves + High Pressure Seal + Rear Drain - 1/4 G (BSPP)		●	/
FP0	Freno FP FP Brake		/	●
DPH	Guarnizione alta pressione + Drenaggio posteriore - 1/4 G (BSPP) High Pressure Seal + Rear Drain - 1/4 G (BSPP)		●	●

● Disponibile - Available / Non Disponibile - Not Available

### 10 - OPZIONI / OPTIONS

XX	Non verniciato Not painted	STANDARD
01	Verniciato RAL 9005 Painted RAL 9005	
02	Verniciato RAL 5015 Painted RAL 5015	
05	Verniciato RAL 7016 Painted RAL 7016	
06	Verniciato RAL 7015 Painted RAL 7015	



**Flangia 2A Flange**  
**Attacchi M08 Main ports**

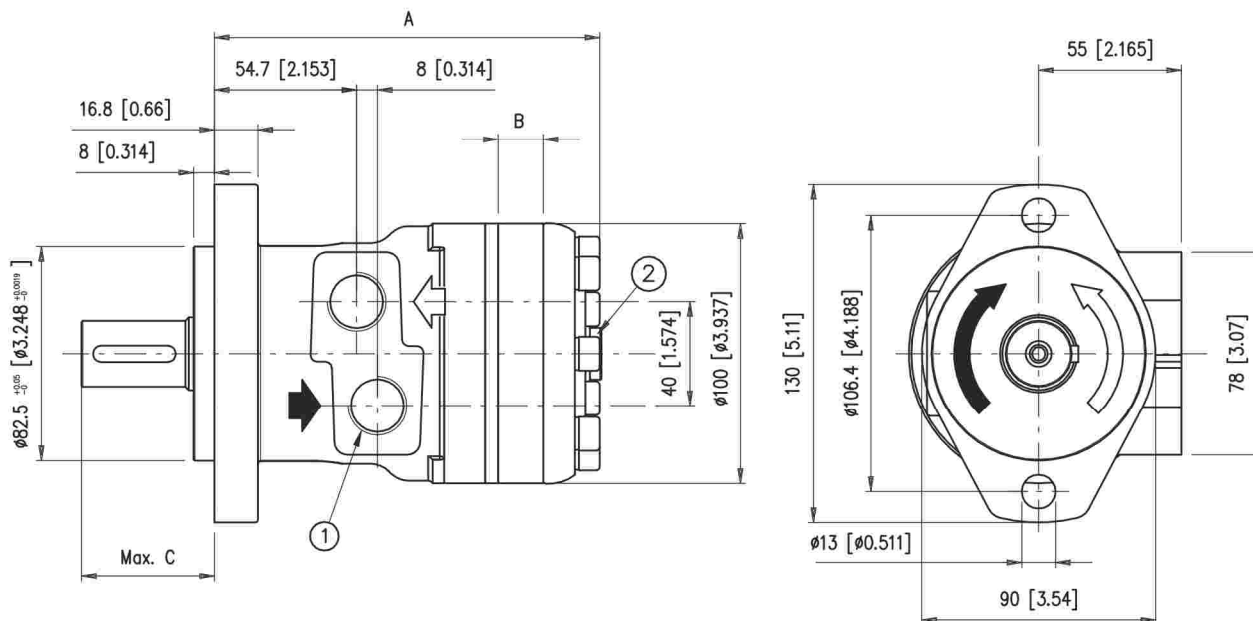

- 1) N° 2 fori di alimentazione 1/2 G (BSPP) profondità filetto 18 mm  
No. 2 1/2 G (BSPP) main ports thread depth 0.70 in
- 2) Drenaggio motore 1/4 G (BSPP) profondità filetto 15 mm Max. Non presente nella versione HPS  
1/4 G (BSPP) drain motor thread depth 0.59 in Max. Not in HPS version.

Per le dimensioni degli alberi vedere pagina E/16  
For shafts dimensions see page E/16

ALBERO SHAFT		CL250	LC254	SD250
C	mm [in]	54 [2.12]	54 [2.12]	54 [2.12]

		BR O 050	BR O 065	BR O 080	BR O 100	BR O 130	BR O 160	BR O 200	BR O 250	BR O 315	BR O 400
A	mm [in]	139.5 [5.49]	141.8 [5.58]	144.5 [5.68]	147.7 [5.81]	152.1 [5.98]	158.2 [6.22]	165.3 [6.50]	173.9 [6.84]	185.1 [7.28]	198.4 [7.81]
B	mm [in]	9 [0.354]	11.3 [0.444]	14 [0.551]	17.4 [0.68]	21.8 [0.85]	27.8 [1.09]	34.8 [1.37]	43.5 [1.71]	54.8 [2.15]	68.38 [2.69]
Pesi Weight	kg [lb]	7.2 [15.8]	7.4 [16.3]	7.5 [16.5]	7.7 [16.9]	8 [17.6]	8.3 [18.2]	8.6 [18.9]	9.1 [20]	9.8 [21.5]	10.1 [22.2]

**Flangia 6A Flange**  
**Attacchi M08 Main ports**

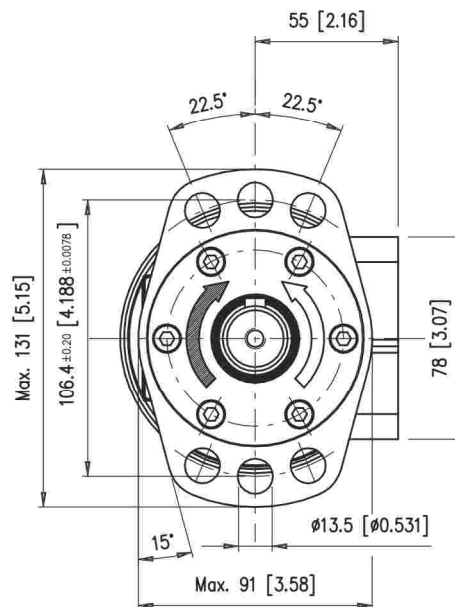
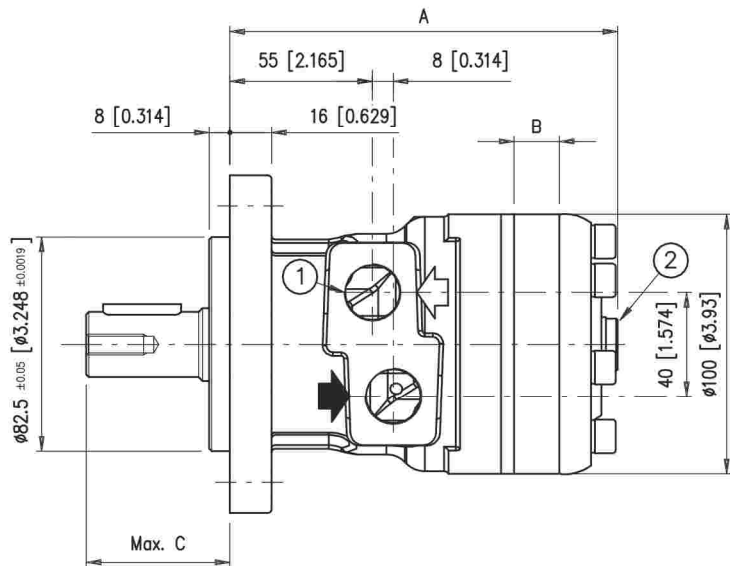

- 1) N° 2 fori di alimentazione 1/2 G (BSPP) profondità filetto 18 mm  
No. 2 1/2 G (BSPP) main ports thread depth 0.70 in
- 2) Drenaggio motore 1/4 G (BSPP) profondità filetto 15 mm.  
1/4 G (BSPP) drain motor thread depth 0.59 in.

Per le dimensioni degli alberi vedere pagina E/16  
For shafts dimensions see page E/16

ALBERO SHAFT		CL250	LC254	SD250	CL320	C3175	CN320				
C	mm [in]	55.3 [2.17]	55.3 [2.17]	55.3 [2.17]	68.3 [2.68]	59.1 [2.32]	68.5 [2.69]				

  

		BR O 050	BR O 065	BR O 080	BR O 100	BR O 130	BR O 160	BR O 200	BR O 250	BR O 315	BR O 400
A	mm [in]	139.5 [5.49]	141.8 [5.58]	144.5 [5.68]	147.7 [5.81]	152.1 [5.98]	158.2 [6.22]	165.3 [6.50]	173.9 [6.84]	185.1 [7.28]	198.4 [7.81]
B	mm [in]	9 [0.354]	11.3 [0.444]	14 [0.551]	17.4 [0.68]	21.8 [0.85]	27.8 [1.09]	34.8 [1.37]	43.5 [1.71]	54.8 [2.15]	68.38 [2.69]
Pesi Weight	kg [lb]	7.3 [16] <sup>1)</sup>	7.5 [16.5] <sup>1)</sup>	7.6 [16.7] <sup>1)</sup>	7.8 [17.1] <sup>1)</sup>	8.1 [17.8] <sup>1)</sup>	8.4 [18.5] <sup>1)</sup>	8.7 [19.1] <sup>1)</sup>	9.2 [20.2] <sup>1)</sup>	9.9 [21.8] <sup>1)</sup>	10.2 [22.4] <sup>1)</sup>
		7.4 [16.3]	7.6 [16.7]	7.7 [16.9]	9 [19.8]	8.3 [18.2]	8.6 [18.9]	9 [19.8]	9.5 [20.9]	10.2 [22.4]	10.5 [23.1]

1) I valori si riferiscono alla versione con albero CL250/LC254/SD250 - The values are referred to CL250/LC254/SD250 shaft

**SPECIALE A RICHIESTA - SPECIAL ON REQUEST**

**Flangia S4 Flange**  
**Attacchi M08 Main ports**

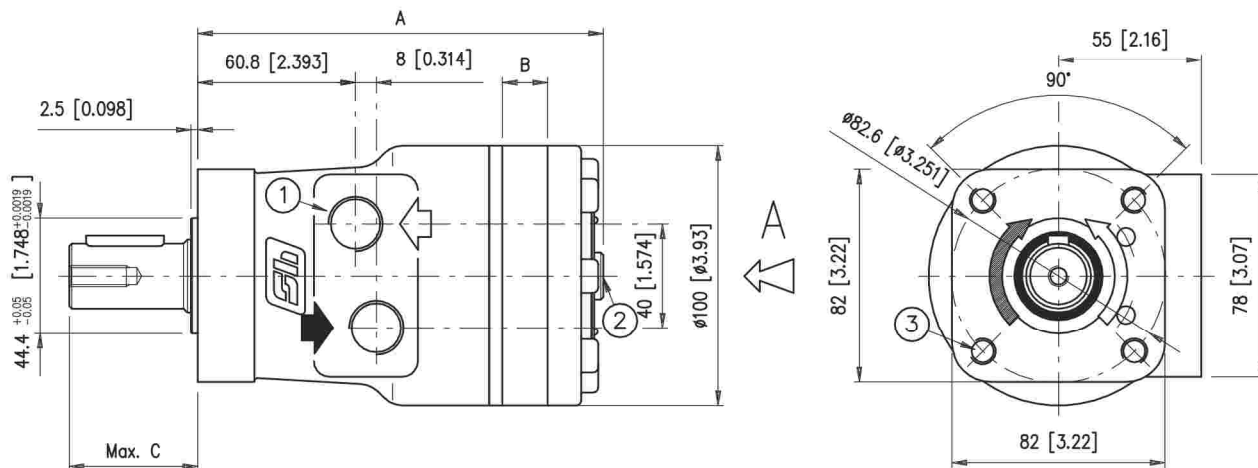

- 1) N° 2 fori di alimentazione 1/2 G (BSPP) profondità filetto 18 mm  
No. 2 1/2 G (BSPP) main ports thread depth 0.70 in
- 2) Drenaggio motore 1/4 G (BSPP) profondità filetto 15 mm.  
1/4 G (BSPP) drain motor thread depth 0.59 in.
- 3) N° 4 3/8" 16 UNC profondità filetto 17 mm  
No. 4 3/8" 16 UNC thread depth 0.66 in

Per le dimensioni degli alberi vedere pagina E/16  
For shafts dimensions see page E/16

ALBERO SHAFT		CL250	LC254	SD250							
C	mm [in]	49.4 [1.94]	49.4 [1.94]	49.4 [1.94]							
		BR O 050	BR O 065	BR O 080	BR O 100	BR O 130	BR O 160	BR O 200	BR O 250	BR O 315	BR O 400
A	mm [in]	147.8 [5.81]	150.1 [5.90]	152.8 [6.01]	156.2 [6.14]	160.6 [6.32]	166.6 [6.55]	173.6 [6.83]	182.3 [7.17]	193.6 [7.62]	207.1 [8.15]
B	mm [in]	9 [0.354]	11.3 [0.444]	14 [0.551]	17.4 [0.68]	21.8 [0.85]	27.8 [1.09]	34.8 [1.37]	43.5 [1.71]	54.8 [2.15]	68.38 [2.69]
Pesi Weight	kg [lb]	7.1 [15.6]	7.3 [16]	7.4 [16.3]	7.6 [16.7]	7.9 [17.4]	8.2 [18]	8.5 [18.7]	9 [19.8]	9.7 [21.3]	10 [22]



**Flangia 2A Flange**  
**Attacchi R08 Main ports**

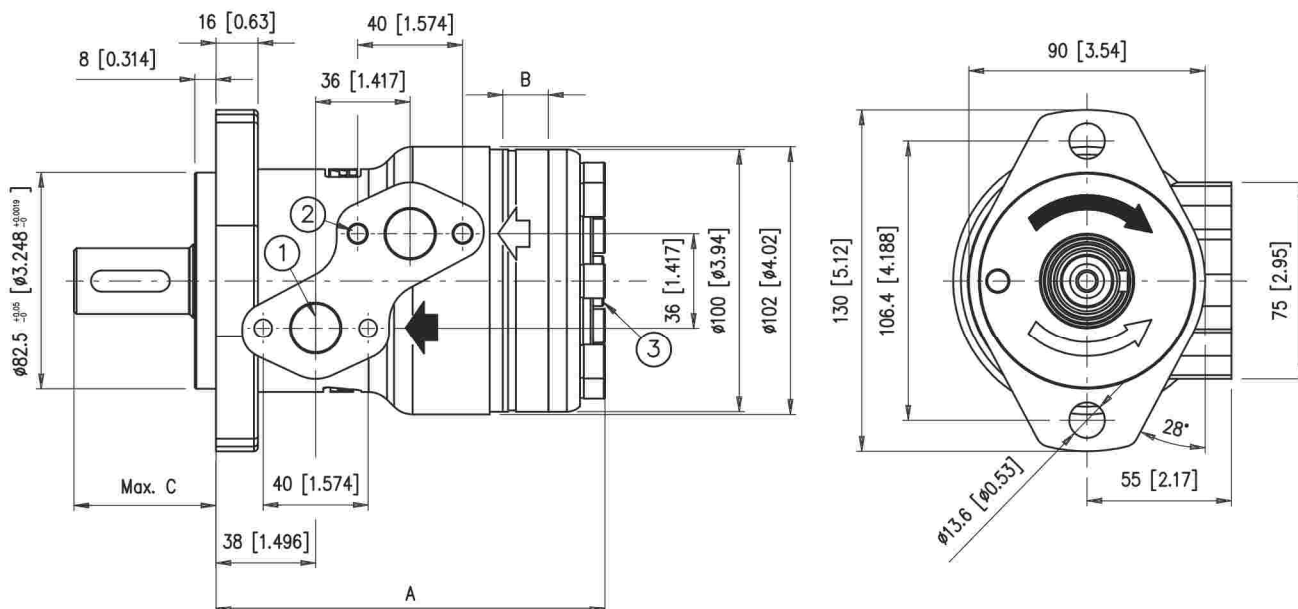

- 1) N° 2 fori di alimentazione 1/2 G (BSPP) profondità filetto 18 mm  
No. 2 1/2 G (BSPP) main ports thread depth 0.70 in
- 2) N° 4 fori M8 tratto utile filetto 15 mm  
No. 4 M8 thread depth 0.59 in
- 3) Drenaggio motore 1/4 G (BSPP) profondità filetto 12 mm (non presente in Versione HPS)  
1/4 G (BSPP) drain motor thread depth 0.472 in (not in HPS version)

Per le dimensioni degli alberi vedere pagina E/16  
For shafts dimensions see page E/16

ALBERO SHAFT		CL250	LC254	SD250							
C	mm [in]	54 [2.12]	54 [2.12]	54 [2.12]							
		BR E 050	BR E 065	BR E 080	BR E 100	BR E 130	BR E 160	BR E 200	BR E 250	BR E 315	BR E 400
A	mm [in]	139.8 [5.50]	142.1 [5.59]	144.8 [5.70]	148.2 [5.83]	152.6 [6.01]	158.6 [6.24]	165.6 [6.52]	174.3 [6.86]	185.6 [7.31]	199.2 [7.84]
B	mm [in]	9 [0.354]	11.3 [0.444]	14 [0.551]	17.4 [0.68]	21.8 [0.85]	27.8 [1.09]	34.8 [1.37]	43.5 [1.71]	54.8 [2.15]	68.38 [2.69]
Peso Weight	kg [lb]	7.2 [15.8]	7.4 [16.3]	7.5 [16.5]	7.7 [16.9]	8 [17.6]	8.3 [18.2]	8.6 [18.9]	9.1 [20]	9.8 [21.5]	10.1 [22.2]

- 1) Drenaggio motore 1/4 G (BSPP) profondità filetto 12 mm  
1/4 G (BSPP) drain motor thread depth 0.472 in
- 2) Attacco sensore M8x1  
Sensor connection M8x1

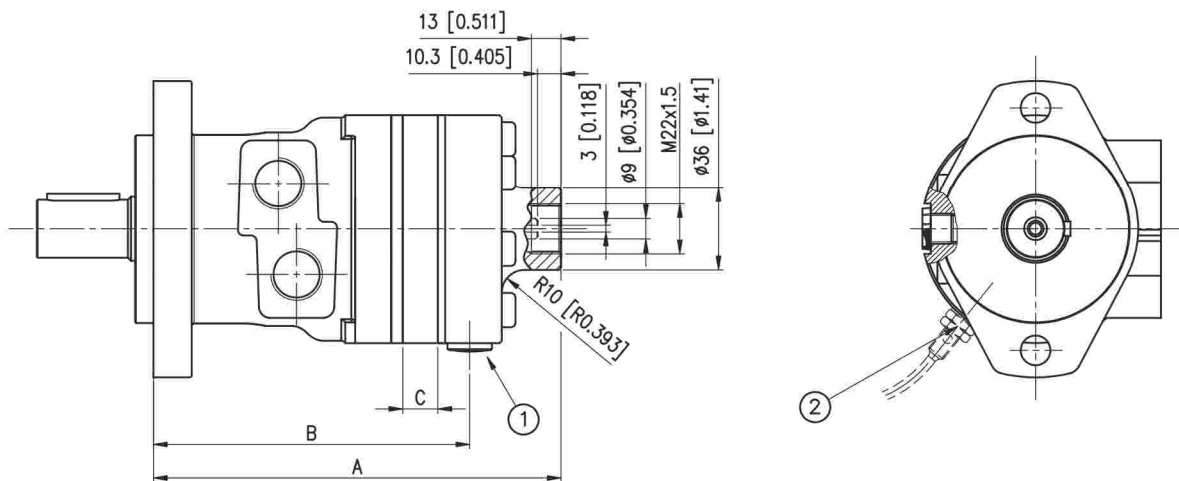

**ATTENZIONE:**

- L'alberino contagiri ha velocità pari a 6 volte quella dell'albero primario del motore e senso di rotazione opposto.
- N.B.: Non sono accettati carichi assiali o radiali sull'albero contagiri. Coppia massima trasmissibile 1 Nm.
- Il motore viene fornito senza il sensore elettronico: se necessario, richiederlo in fase di ordinazione.
- Pressione massima ammessa sulla guarnizione dell'albero contagiri con drenaggio chiuso: 25 bar.

**WARNING:**

- Tacho shaft has a 6 times higher revolution speed than the motor shaft and opposite direction of rotation.
- NOTE: Axial or radial load on tacho shaft must be avoided. Max torque on tacho 1 Nm [0.737 lbf-ft].
- The electronic sensor is not supplied: if required, please state it clearly on order form.
- Max pressure admissible on the shaft seal with closed drain port 25 bar [362.5 psi].

		BR O 050	BR O 065	BR O 080	BR O 100	BR O 130	BR O 160	BR O 200	BR O 250	BR O 315	BR O 400
<b>A</b>	<b>mm [in]</b>	172 [6.77]	174.3 [6.86]	177 [6.96]	180.4 [7.10]	184.8 [7.27]	190.8 [7.51]	197.8 [7.78]	206.5 [8.12]	217.8 [8.57]	231.3 [9.10]
<b>B</b>	<b>mm [in]</b>	132 [5.19]	134.3 [5.28]	137 [5.39]	140.4 [5.52]	144.8 [5.70]	150.8 [5.93]	157.8 [6.21]	166.5 [6.55]	177.8 [7.00]	191.3 [7.53]
<b>C</b>	<b>mm [in]</b>	9 [0.354]	11.3 [0.444]	14 [0.551]	17.4 [0.68]	21.8 [0.85]	27.8 [1.09]	34.8 [1.37]	43.5 [1.71]	54.8 [2.15]	68.38 [2.69]
<b>Pesi Weight</b>	<b>kg [lb]</b>	7.7 [16.9]	7.9 [17.4]	8 [17.6]	8.2 [18]	8.5 [18.7]	8.8 [19.3]	9.1 [20]	9.6 [21.1]	10.3 [22.7]	10.6 [23.3]

**CARATTERISTICHE TECNICHE SENSORE ELETTRONICO**  
**ELECTRONIC SENSOR TECHNICAL FEATURES**

Segnale in uscita versione elettronica  
Output signal electronic tacho

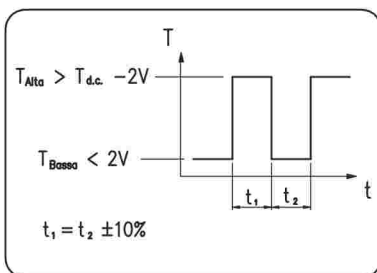

Numero d'impulsi per giro = 90  
Principio di funzionamento induttivo  
Funzione di uscita PNP  
Tensione nominale 10-65 V d.c.  
Caricabilità massima 300 mA  
Frequenza massima 10000 Hz  
Campo di temperatura -25C +85C  
Grado di protezione IP 67

Versioni disponibili:

- Sensore con cavo a tre fili lunghezza 2 metri (cod. 424.0050.0000)
- Sensore con attacco per connettore tipo binder (cod. 424.0060.0000) + connettore tipo binder
- Con cavo a tre fili lunghezza 5 metri (cod. 424.0080.0000)

Number of pulses per revolution = 90  
Inductive principle  
Output current PNP  
Voltage 10-65 V d.c.  
Max load 300 mA  
Max frequency 10000 Hz  
Temperature range -25C +85C  
Enclosure IP 67

Available versions:

- Sensor with 2 metres three wires cable (cod. 424.0050.0000)
- Sensor with binder plug connection (cod. 424.0060.0000) + binder connecting plug with 5 metres three wires cable (cod. 424.0080.0000)

1) Drenaggio motore 1/4 G (BSPP) profondità filetto 13mm  
1/4 G (BSPP) drain motor thread depth 0.511 in

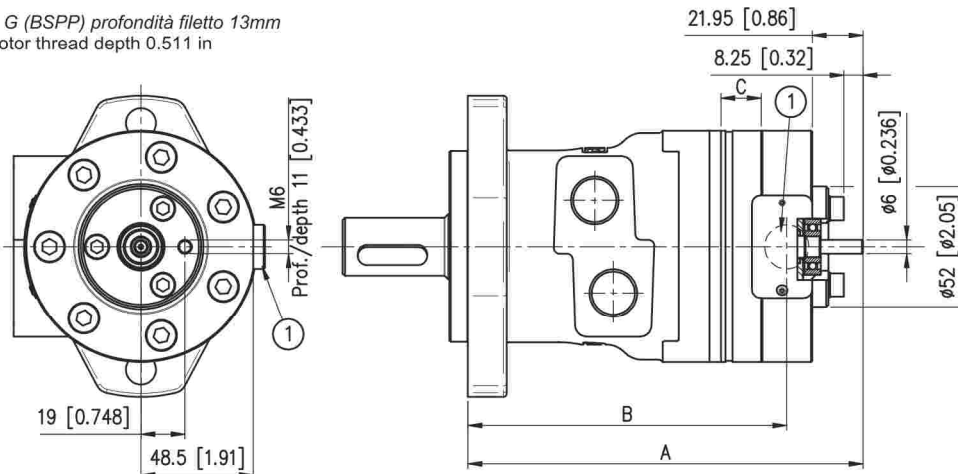

**ATTENZIONE:**

- L'alberino contagiri ha velocità pari a 6 volte quella dell'albero primario del motore e senso di rotazione opposto.
- N.B.: Non sono accettati carichi assiali o radiali sull'albero contagiri.

**WARNING:**

- Tacho shaft has a 6 times higher revolution speed than the motor shaft and opposite direction of rotation.
- NOTE: Axial or radial load on tacho shaft must be avoided.

		BR O 050	BR O 065	BR O 080	BR O 100	BR O 130	BR O 160	BR O 200	BR O 250	BR O 315	BR O 400
A	mm [in]	162.2 [6.38]	164.5 [6.48]	167.2 [6.58]	170.5 [6.71]	175 [6.89]	181 [7.12]	188 [7.40]	196.6 [7.74]	208 [8.19]	221.5 [8.72]
B	mm [in]	129.3 [5.09]	131.6 [5.18]	134.3 [5.29]	137.7 [5.42]	142.1 [5.59]	148.1 [5.83]	155.1 [6.11]	163.8 [6.45]	175.1 [6.89]	188.7 [7.43]
C	mm [in]	9 [0.354]	11.3 [0.444]	14 [0.551]	17.4 [0.68]	21.8 [0.85]	27.8 [1.09]	34.8 [1.37]	43.5 [1.71]	54.8 [2.15]	68.38 [2.69]
Pesi / Weight	kg [lb]	7.7 [16.9]	7.9 [17.4]	8 [17.6]	8.2 [18]	8.5 [18.7]	8.8 [19.3]	9.1 [20]	9.6 [21.1]	10.3 [22.7]	10.6 [23.3]

1) Drenaggio motore 1/4 G (BSPP) profondità filetto 13mm  
1/4 G (BSPP) drain motor thread depth 0.511 in

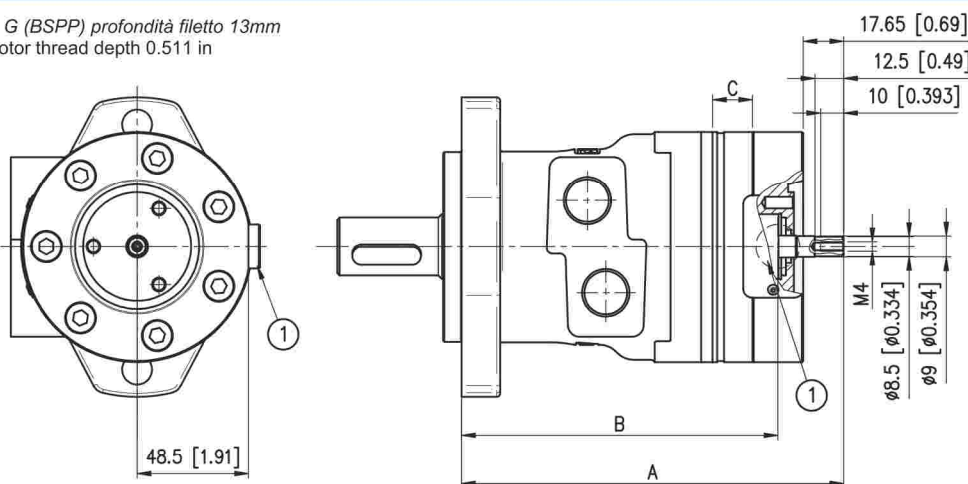

**ATTENZIONE:**

- L'alberino contagiri ha velocità pari a 6 volte quella dell'albero primario del motore e senso di rotazione opposto.
- N.B.: Non sono accettati carichi assiali o radiali sull'albero contagiri.

**WARNING:**

- Tacho shaft has a 6 times higher revolution speed than the motor shaft and opposite direction of rotation.
- NOTE: Axial or radial load on tacho shaft must be avoided.

		BR O 050	BR O 065	BR O 080	BR O 100	BR O 130	BR O 160	BR O 200	BR O 250	BR O 315	BR O 400
A	mm [in]	157.9 [6.21]	160.2 [6.31]	162.9 [6.41]	166.2 [6.54]	170.7 [6.72]	176.7 [6.96]	183.7 [7.23]	192.3 [7.57]	203.7 [8.02]	217.2 [8.55]
B	mm [in]	129.3 [5.09]	131.6 [5.18]	134.3 [5.29]	137.7 [5.42]	142.1 [5.59]	148.1 [5.83]	155.1 [6.11]	163.8 [6.45]	175.1 [6.89]	188.7 [7.43]
C	mm [in]	9 [0.354]	11.3 [0.444]	14 [0.551]	17.4 [0.68]	21.8 [0.85]	27.8 [1.09]	34.8 [1.37]	43.5 [1.71]	54.8 [2.15]	68.38 [2.69]
Pesi / Weight	kg [lb]	7.7 [16.9]	7.9 [17.4]	8 [17.6]	8.2 [18]	8.5 [18.7]	8.8 [19.3]	9.1 [20]	9.6 [21.1]	10.3 [22.7]	10.6 [23.3]



- 1) Comando apertura freno 1/4 G (BSPP) profondità filetto 13mm  
1/4 G (BSPP) brake releasing thread depth 0.511 in  
2) Drenaggio motore 1/4 G (BSPP) profondità filetto 13mm  
1/4 G (BSPP) drain motor thread depth 0.511 in

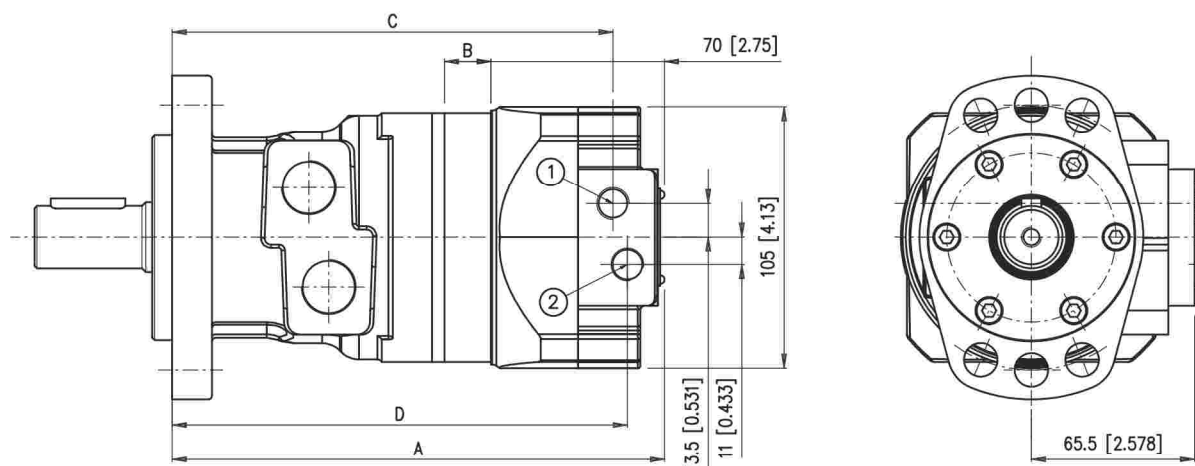

		BR O 050	BR O 065	BR O 080	BR O 100	BR O 130	BR O 160	BR O 200	BR O 250	BR O 315	BR O 400
<b>A</b>	mm [in]	187.9 [7.39]	190.2 [7.48]	192.9 [7.59]	196.3 [7.72]	200.7 [7.90]	206.7 [8.13]	213.7 [8.41]	222.4 [8.75]	233.7 [9.20]	247.2 [9.73]
<b>B</b>	mm [in]	9 [0.354]	11.3 [0.444]	14 [0.551]	17.4 [0.68]	21.8 [0.85]	27.8 [1.09]	34.8 [1.37]	43.5 [1.71]	54.8 [2.15]	68.38 [2.69]
<b>C</b>	mm [in]	169.9 [6.68]	172.2 [6.77]	174.9 [6.88]	178.3 [7.01]	182.7 [7.19]	188.7 [7.42]	195.7 [7.70]	204.4 [8.04]	215.7 [8.49]	229.2 [9.02]
<b>D</b>	mm [in]	173 [6.81]	175.3 [6.90]	178 [7.00]	181.4 [7.14]	185.8 [7.31]	191.8 [7.55]	198.8 [7.82]	207.5 [8.16]	218.8 [8.61]	232.2 [9.14]
<b>Pesi Weight</b>	kg [lb]	8.2 [18]	8.4 [18.5]	8.5 [18.7]	8.7 [19.1]	9 [19.8]	9.3 [20.4]	9.6 [21.1]	10.1 [22.2]	10.8 [23.8]	11.1 [24.4]

**CARATTERISTICHE FRENO**  
**BRAKE FEATURES**

I freni integrati nei motori FP sono freni di stazionamento a sbloccaggio idraulico (freni negativi) e non possono essere impiegati per frenare dinamicamente il carico.

The brakes integrated in FP motors are holding brakes type (negative brake) and cannot be used for dynamic braking action.

**Accorgimenti per l'installazione**

**Installation layout**

- Il motore idraulico con freno posteriore FP richiede obbligatoriamente il collegamento del drenaggio motore, posto sul corpo freno, in serbatoio a scarico libero.
- Nel caso di funzionamento in circuito aperto è consigliato l'utilizzo di una valvola di ritardo chiusura freno ( per evitare il funzionamento dinamico dello stesso) di una valvola overcentre e di un distributore a centro aperto.
- The FP hydraulic motors must always have the drain port (on casing) directly connected with tank
- If open circuit layout is needed, it is advisable to use a flow control valve on brake piston ports (in order to avoid dynamic braking), on overcentre valve and a open-centre directional valve.

Caratteristiche del motore-freno		Motor-brake features
Pressione di apertura minima	22 bar [319 psi]	Minim release pressure
Pressione di freno libero	25 bar [362.5 psi]	Complete brake release pressure
Pressione massima sul freno	160 bar [2320 psi]	Max. brake pressure
Coppia massimastica	370 Nm [272.7 lbf-ft]	Max. static torque
Velocità massima motore	350 rpm	Max. motor speed

**ALBERO CILINDRICO CL250**  
CL250 CYLINDRICAL SHAFT

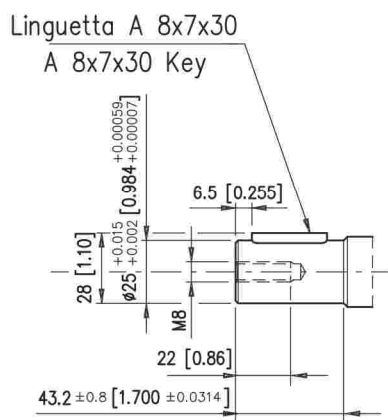

**ALBERO CILINDRICO LC254**  
LC254 CYLINDRICAL SHAFT

Linguetta A 1/4"x1/4"x1/4 BS46  
A 1/4"x1/4"x1/4 BS46 Key

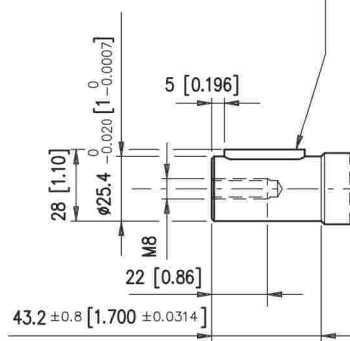

**ALBERO SCANALATO SD250**  
SD250 SPLINED SHAFT

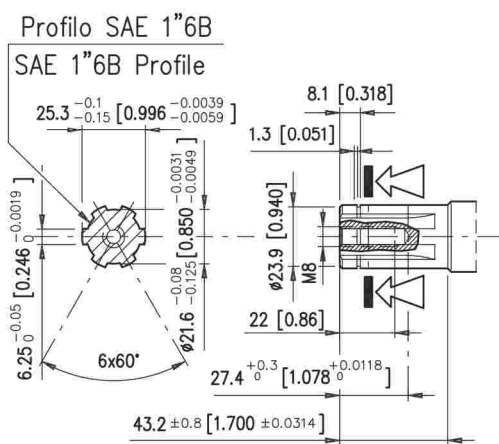

**ALBERO CILINDRICO CL320**  
CL320 CYLINDRICAL SHAFT

Linguetta A 10x8x40  
A 10x8x40 Key

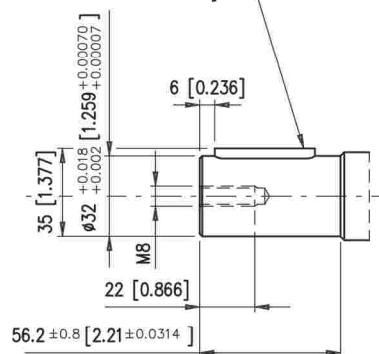

**ALBERO CILINDRICO C3175**  
C3175 CYLINDRICAL SHAFT

Linguetta A 5/16x5/16x1.1/4 UNI 6604  
A 5/16x5/16x1.1/4 Key

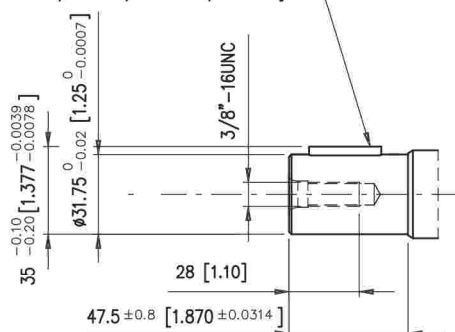

**ALBERO CONICO CN320**  
CN320 TAPERED SHAFT

Linguetta 6x9 UNI 6606-69  
6x9 UNI 6606-69 key

Conicità' 1:10  
1:10 taper

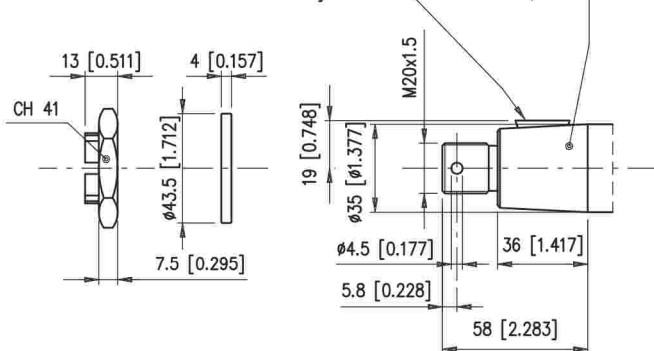

# CARICHI AMMESSI SULL'ALBERO SHAFT LOAD CAPACITY

I carichi ammessi sull'albero variano in funzione di:

- Velocità (n)
- Distanza (L) dal punto di applicazione del carico alla flangia di montaggio
- Versione della flangia di montaggio
- Versione dell'albero

Formula utilizzabile per il calcolo del carico radiale (Pr) ai vari numeri di giri (n), e alle varie distanze (L) dalla flangia tipo "2A" ovale 2 fori e "6A" ovale 6 fori.

Radial load capacity (Pr) cur ve according to speed (n) and distance (L) from flange, valid for the 2-bolt flange type "2A" and 6-bolt flange type "6A"

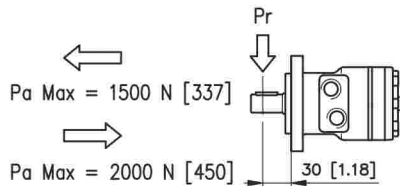

	Flangia / Flange 2A	Flangia / Flange 6A
alberi / shafts CL250 LC254 SD250	$Pr = \frac{800}{n} \cdot \frac{250000}{95 + L}$ [N]	$Pr = \frac{800}{n} \cdot \frac{250000}{95 + L}$ [N]
alberi / shafts C3175 CL320 CN320		$Pr = \frac{800}{n} \cdot \frac{187500}{95 + L}$ [N]

Formula valida per n >= 200 rpm  
Per n < 200 rpm Pmax = 8000 N

This formula being valid for n >= 200 rpm  
For n < 200 rpm Pmax = 8000 N [1800 lbf]

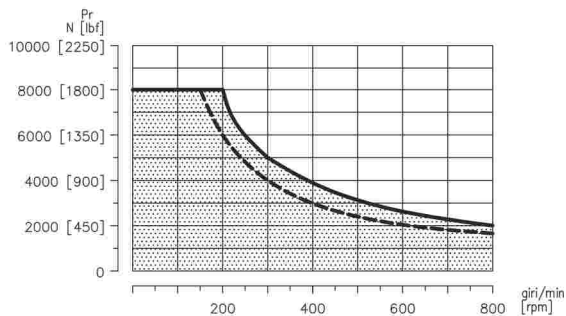

The permissible radial shaft load depends on

- Speed (n)
- Distance (L) from the point of load to the mounting flange
- Mounting flange version
- Shaft version

Formula utilizzabile per il calcolo del carico radiale (Pr) ai vari numeri di giri (n), e alle varie distanze (L) dalla flangia tipo "S4" 4 fori.

Radial load capacity (Pr) cur ve according to speed (n) and distance (L) from flange, valid for the 4-bolt flange type "S4".

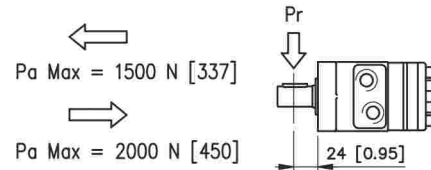

	Flangia / Flange S4
alberi / shafts CL250 LC254 SD250	$Pr = \frac{800}{n} \cdot \frac{242000}{97 + L}$ [N]

Formula valida per n >= 200 rpm  
Per n < 200 rpm Pmax = 8000 N

This formula being valid for n >= 200 rpm  
For n < 200 rpm Pmax = 8000 N [1800 lbf]

La curva mostra la relazione tra (Pr) e (n) quando:

- L = 30 mm [1.18 in] per motori flangia 2A e 6A
- L = 24 mm [0.95 in] per motori flangia S4

The curve show the relation between (Pr) and (n)

- L = 30 mm [1.18 in] for motors with 2A and 6A flange
- L = 24 mm [0.95 in] for motors with S4 flange

--- Per alberi C3175-CL320-CN320  
For shafts C3175-CL320-CN320  
— Per alberi CL250-LC254-SD250  
For shafts CL250-LC254-SD250